

Main applications

- Industrial furnaces for heat treatments, metallurgy
- Fusion, sinterization, nitration furnaces
- Furnaces for ceramics and precious metals
- Dryers
- Heating systems with infrared lamps (long-, medium-, short-wave)
- Wood edge banding Machines
- Plastic-blowing Machines
- Welding applications on Packaging Machinery
- Thermoforming Machines
- Furnaces with Super Kanthal™ Silicon carbide heating elements



Main features

- Current levels from 40A to 250A
- Rated voltage 480Vac to 600Vac and 690Vac
- Trigger configurable in "Zero crossing" (Fixed Cycle, Burst Firing, Half single Cycle) or "Phase angle"
- Analog control input, configurable in: Volt, mA, potentiometer (digital in PWM)
- Incorporated Resettable Electronic fuse (optional)
- Total and partial load interrupt alarm (HB) (optional)
- Communication Modbus RTU, RS 485 2 wires (optional)
- Current limit (optional)
- V, I, P feedback (optional)
- Connections for monophase and triphase applications (just in zero crossing" mode)
- Configuration from PC (by USB – TTL cable)
- CE, TÜV, UL Marking (pending)

PROFILE

The "GTF plus" series of microprocessor advanced solid state power unit controls, in compact and optimized solutions, offer various power outputs for use with different types of heating elements.

Current levels range from 25A to 250A, nominal voltage from 480Vac to 600Vac.

The command input is configurable and accepts 0-10V, 0/4-20mA signals, potentiometers, logic signals, including with PWM modes for cost effective solutions.

The device can also be operated via Modbus RTU serial communication, with cascade chain connections facilitated by plug-in RJ10 (telephone) connectors.

The many trigger modes are software configurable and provide:

- **ZC:** Zero Crossing constant cycle time (settable in range 1-200sec), for conventional loads

- **BF:** Burst-Firing, Zero crossing with optimized minimum cycle time, for systems with low thermal inertia, medium-wave IR lamps

- **HSC:** Half Single Cycle Zero Crossing (corresponding to Burst Firing) that manages single semi-cycles of conduction or stop cycles, useful for short-wave IR lamps, reduces flickering and limits generation of EMC noise on the power line (applied only to single-phase load or 3-phase open delta 6 leads)

- **PA:** Phase angle control, useful for short-wave IR lamps, transformer primaries. Completely eliminates flickering of load filaments.

Soft Start and soft stop ramp functions can be assigned to these controls with limitation of current peaks and/or maximum RMS current level.

Thanks to sophisticated Hardware and Software solutions, you can precisely control different types of loads.

Phase angle control matched with **current limit** and **current, voltage, or load power feedback** functions, can be used with "critical" applications such as (for

example), special resistors such as special Super Kanthal™ heating elements, Silicon Carbide resistors, or transformer primaries.

GTF runs complete diagnostics of current, voltage, power, and temperature levels:

Current Diagnostics:

- Total and partial load interrupt alarm
- Self-learn function of alarm limit for interrupted load
- Alarm for SCR in short circuit
- Alarm for load in short circuit or overcurrent
- Alarm for interrupted internal fuse

Voltage Diagnostics:

- Alarm for absence of phase

Temperature Diagnostics:

- Alarm for over temperature of power module

The power control with Soft start ramp limits load current peaks at power-on, optimizes the consumptions and increases the load operating duration.

A specific, linear Soft Start curve, designed to control gradually the current in the initial phase is available for IR lamps. The internal **resettable “electronic fuse”** is an exclusive option: it lets you avoid extra-rapid fuses and greatly reduces machine downtimes and their cost.

Device parameters can be configured from PC, by means of a simple configuration SW which lets you save all parameters in a configuration file that is easy to manage and to copy to other devices. Moreover, an RS485 serial connection of GTF is offered with Modbus RTU protocol

to control currents, voltages, powers, load status, and device status from the supervisor terminal (HMI) or PLC.

MODELS

General features:

Nominal voltage: 480 or 600V
Nominal current: 25, 40, 50, 60, 75, 90, 120, 150, 200, 250 Arms @ 40°C in continuous service.

IsolationHV

Rated isolation voltage input/output:
4000Vac

INPUTS

Control analog input

Voltage: 5Vdc, 10Vdc
Current: 0...20mA, 4...20mA
Potentiometer: from 1k ohm to 10k ohm (auto-fed by 5V from GTF)

Digital inputs

Range 5-30V max 7mA
PWM input control: max 100Hz (Configurable Features).

Voltage line range

Range: 90... V_nominal_product
Frequency: 50-60Hz

Current load range

Range: 0... 2*I_nominal_product

Key HB:

HB alarm calibration ON or reset memory alarms

OUTPUTS

Power output, function mode:

PA – Phase Angle
HSC – Half Single Cycle
BF – Burst Firing (Zero-crossing minimum optimize cycle time)
ZC – Zero Crossing fixed cycle time

Potentiometer power output:

5Vdc max 10mA

Master/Slave control output:

7.5Vdc max 25mA (to synchronize another GTF or to control a GTS solid state power unit)

HB alarm output (optional)

Normally open contact (max 30V, 150mA, maximum conduction resistance 15Ω).

The HB function detects partial or total load interruption.

The control measures load current by means of an internal device.

The current limit value is set via an automatic procedure activated with the HB button located near the upper connector.

The alarm state closes the output contact.

Thermic Dissipation:

GTF models with internal SCR dissipate thermic power based on load current:

$$P_{dissipation} = I_{load_Arms} * 1.3V (W)$$

For 150, 200, 250 A models with integrated fuse, also consider dissipated power at rated current shown on the fuse table
GTF models with electronic fuse (with internal IGBT) dissipate thermic power based on load current:

$$P_{dissipation} = I_{load_Arms} * 2.8V (W)$$

Fuse:

GTF 25-120: fitted externally
GTF 150-250 : internal (optional)

Electronic fuse (optional)

This option eliminates the need for an external extra-rapid fuse to protect the device. In case of load short-circuit, the internal IGBT device is instantaneously switched off and the alarm status is signaled.

Installation notes:

- To ensure maximum reliability, it is essential to install the unit correctly in the panel in order to guarantee adequate heat exchange between the heat sink and the room under natural convection conditions.
- Install the unit vertically (max 10° inclination from vertical axis).
- Vertical distance between unit and panel wall >100mm
- For model without electronic fuse, use the high speed fuses specified in the catalog

- Applications with solid state power units must also include an automatic safety switch to cut out the load power line.

Limits of use

- Dissipation of thermic power on the device with restraints on the ambient temperature of the installation.
- Equip the cabinet with an external air change or air-condition it, to put out dissipated power.
- Installation restraints (distances to be respected to grant dissipation with natural convection).
- Line transistor max. voltage and derivative limits, for which the solid state relay is equipped with inside safety devices (based on the models)
- Presence of load current dispersion (range 5-20mA depending on model) in absence of thyristor conduction due to internal RC protections.

TTL serial port

In standard models (without RS485 serial option) this port lets you connect GTF to a PC to configure initially the operating internal parameters. NB: this port must NOT be used during the normal device operation.

Modbus RS485 serial (optional)

This option lets you connect the device to a PC, PLC, HMI with a simple RJ10 telephone wire, by using an RS485 serial line with Modbus protocol.

The Baud-Rate is configurable from 1200 Baud to 19200 Baud.

A pair of rotary-switches lets you quickly assign the node address. A dip-switch near the rotary-switches lets you internally insert the line termination resistance.

The RJ10 double connector lets you quickly connect several GTF devices to an unique Modbus master in cascade (PC, PLC, HMI, ...)

DESCRIPTION OF CONNECTIONS GTF 25-120A

Top view
WITH OUT option Fieldbus

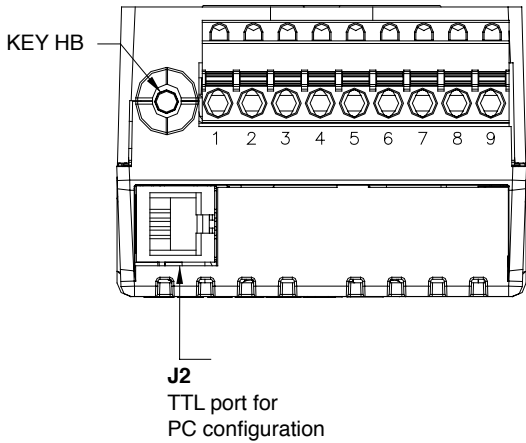

Top view
WITH option Fieldbus

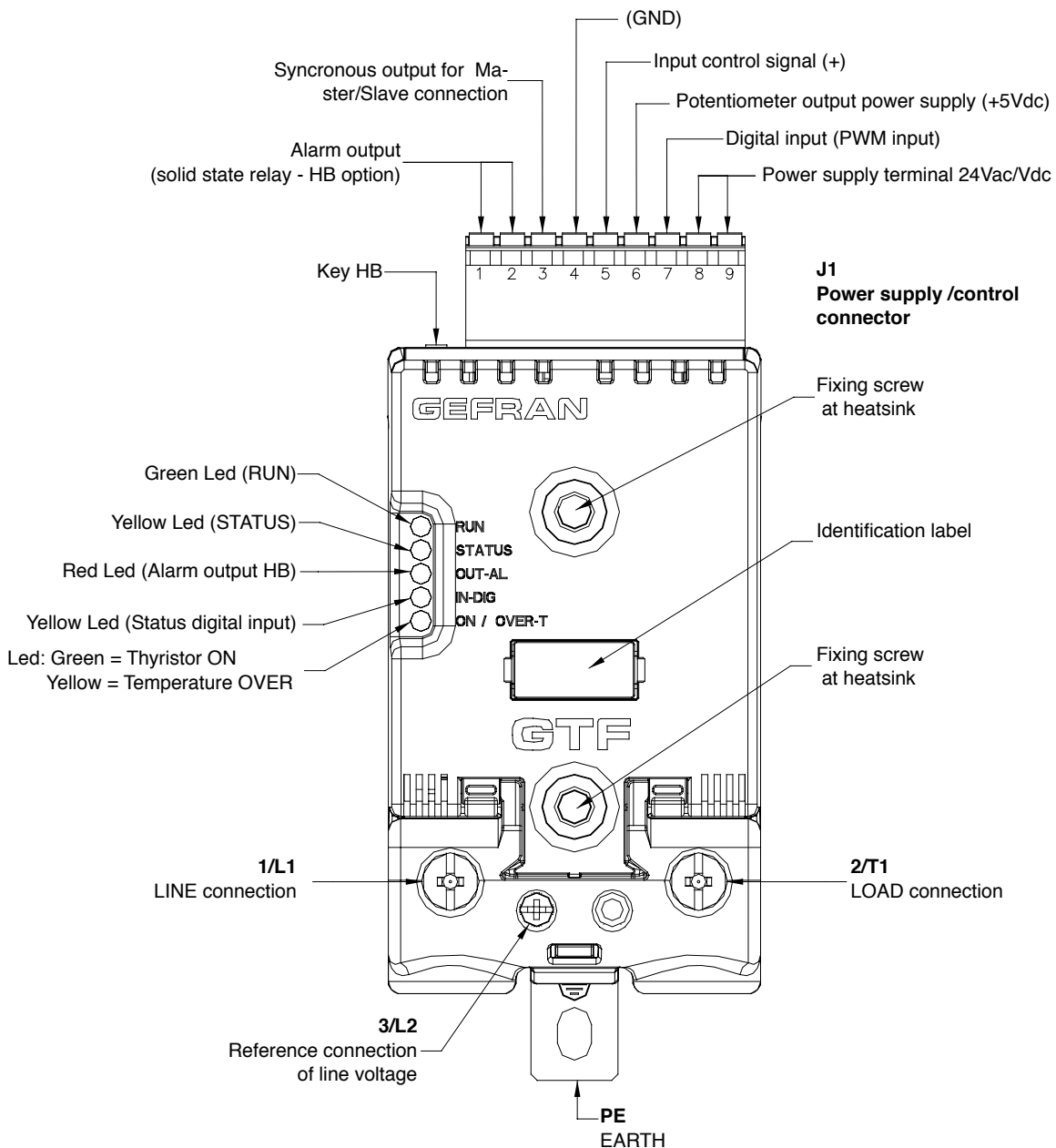
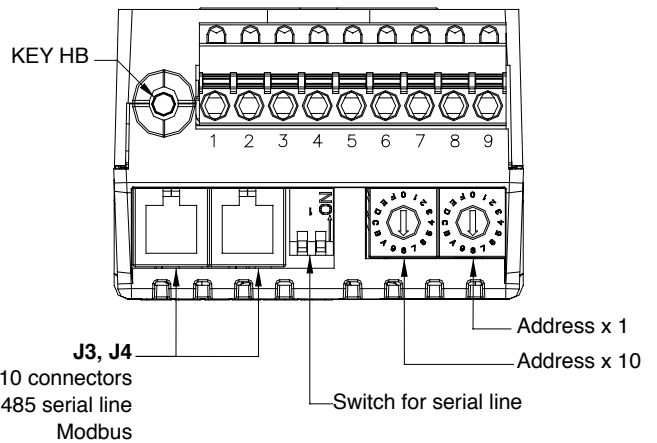

GTF 150-250A DESCRIPTION OF CONNECTIONS

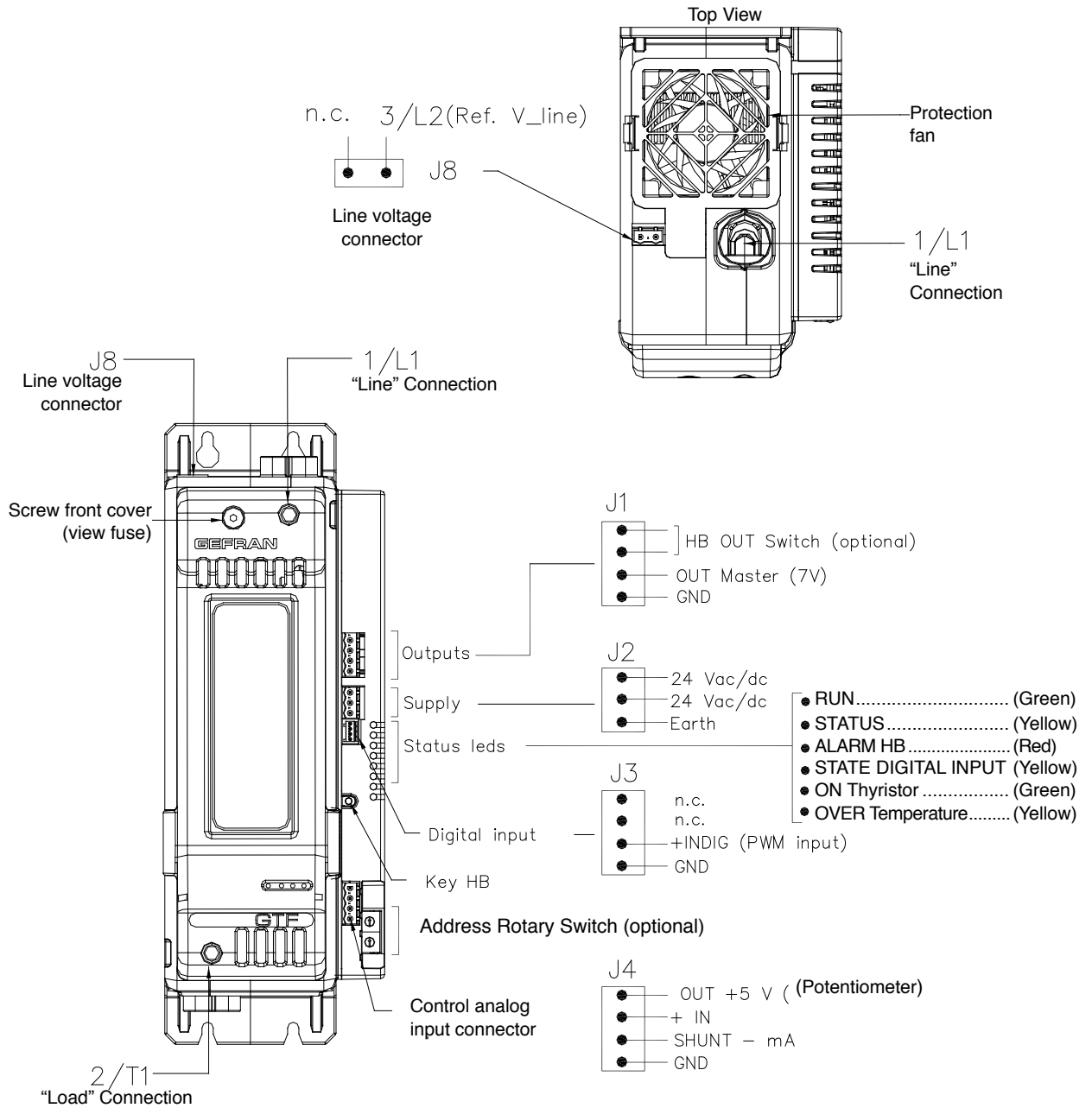

Low view WITHOUT option RS485 serial line

Low view WITH option RS485 serial line

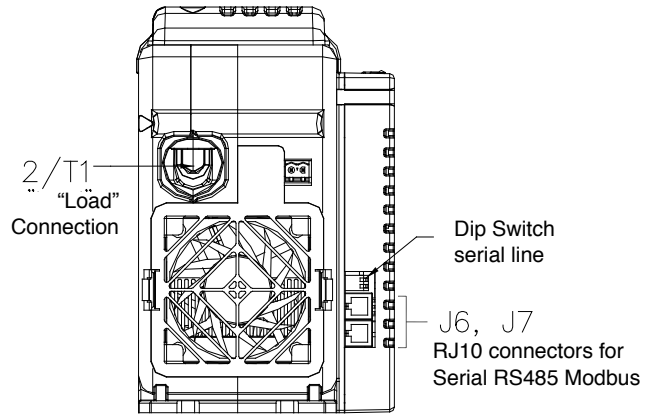
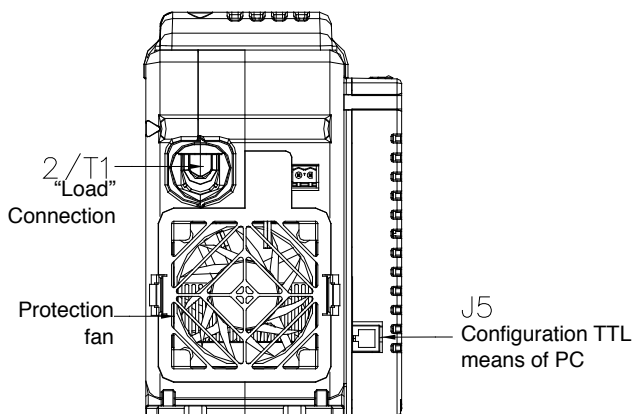

DERATING CURVES GTF (SCR)

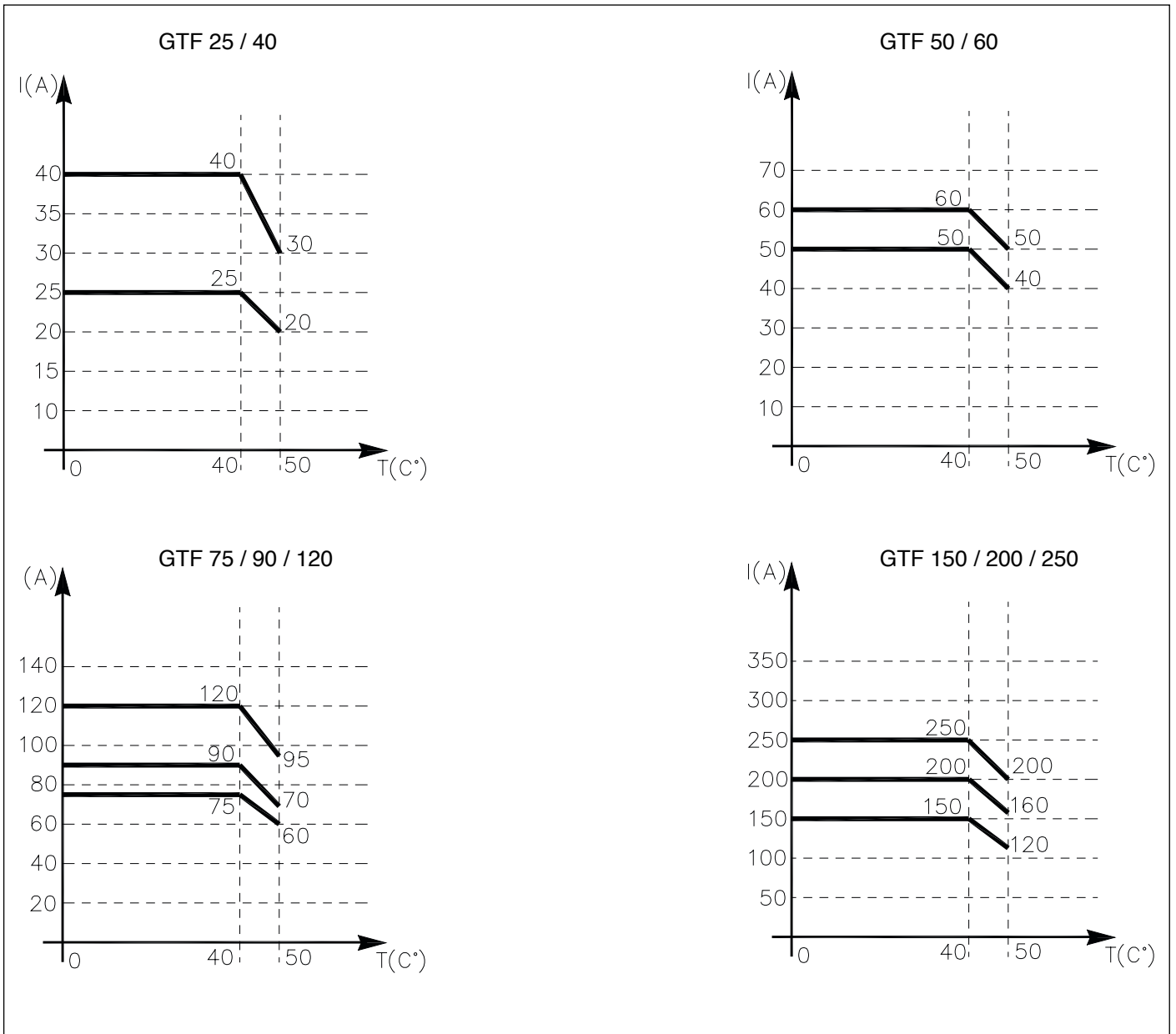

DERATING CURVES GTF with electronic fuse (IGBT)

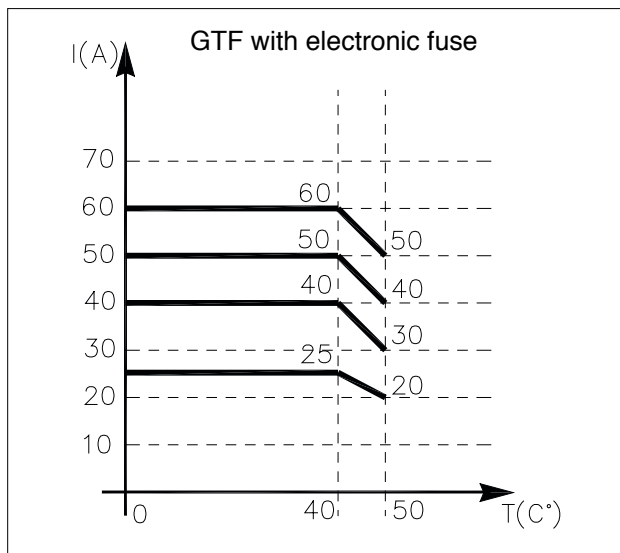

FUNCTION MODE

Trigger modes

The GTF provides the following power control modes:

- modulation via variation of phase angle: PA modality
- modulation via variation of number of conduction cycles with "zero crossing" trigger": ZC, BF, HSC modality.

PA - Phase angle

This mode manages power on the load by modulating load phase angle (only mono-phase)

ex: if power to be transferred to the load is 100%, $\theta = 180^\circ$

ex: if power to be transferred to the load is 50%, $\theta = 90^\circ$

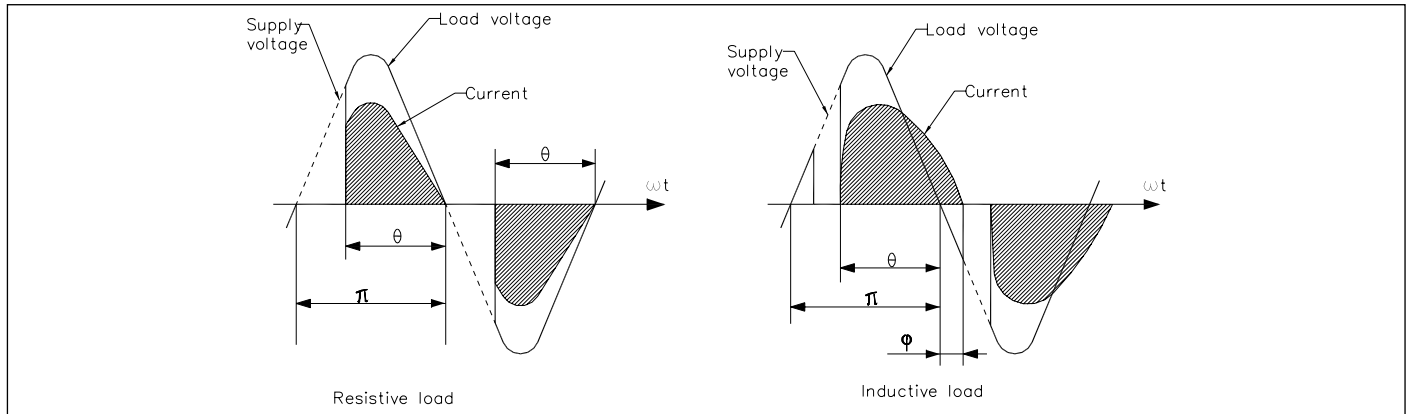

Zero Crossing mode

This function eliminates EMC noise. This mode controls power on the load via a series of conduction ON and non conduction OFF cycles.

ZC - Zero Crossing constant cycle time ($T_c \geq 1$ sec, settable from 1 to 200 sec) Cycle time is divided into a series of conduction and non conduction cycles in proportion to the power value to be transferred to the load. (mono-phase or bi-phase).

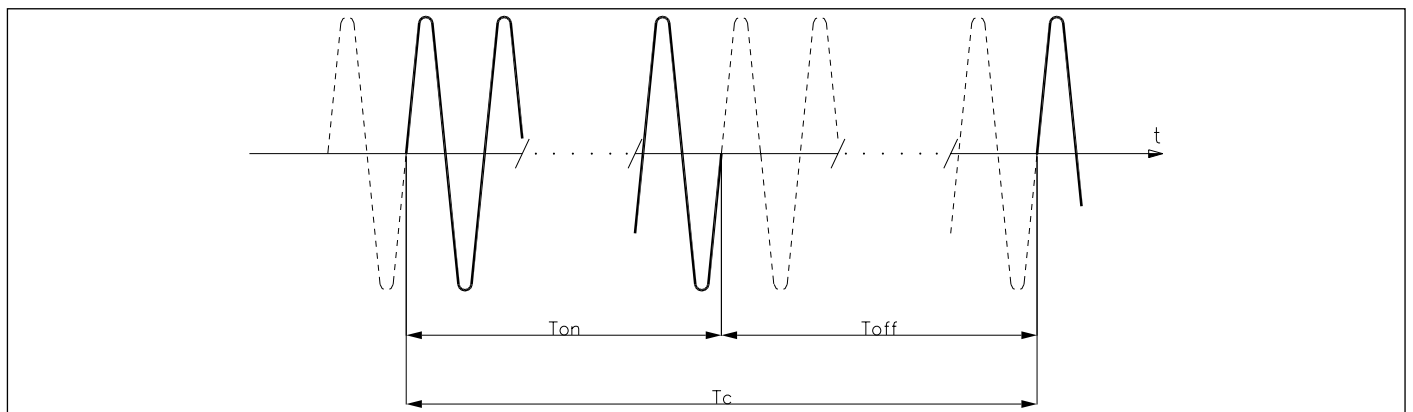

For example, if $T_c = 10$ sec, if the power value is 20% there is conduction for 2 sec (100 conduction cycles @ 50Hz) and non conduction for 8 sec (400 non conduction cycles @ 50Hz).

BF - Burst Firing, Zero Crossing variable cycle time (mono-phase or bi-phase).

This mode controls power on the load via a series of conduction ON and non conduction OFF cycles. The ratio of the number of ON cycles to OFF cycles is proportional to the power value to be supplied to the load.

The CT repeat period is kept to a minimum for each power value (whereas in ZC mode the period is always fixed and not optimized).

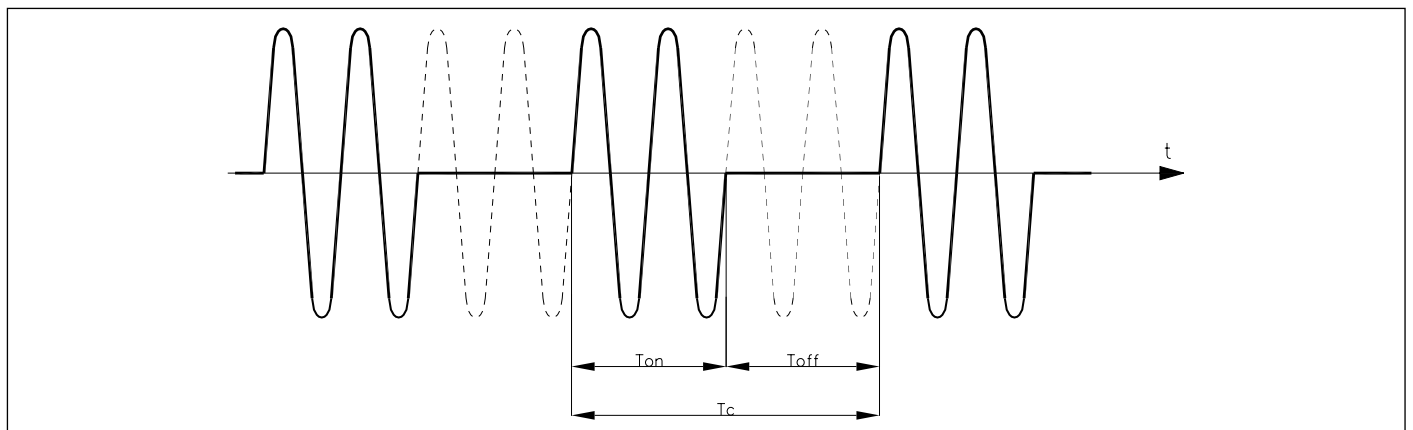

Example of operation in BF mode with power at 50%. A parameter defines the minimum number of conduction cycles settable (from 1 to 10). In the example, this parameter = 2.

FUNCTION MODE

HSC - Half single cycle

This mode corresponds to Burst Firing that manages Semi-cycles of on and off..

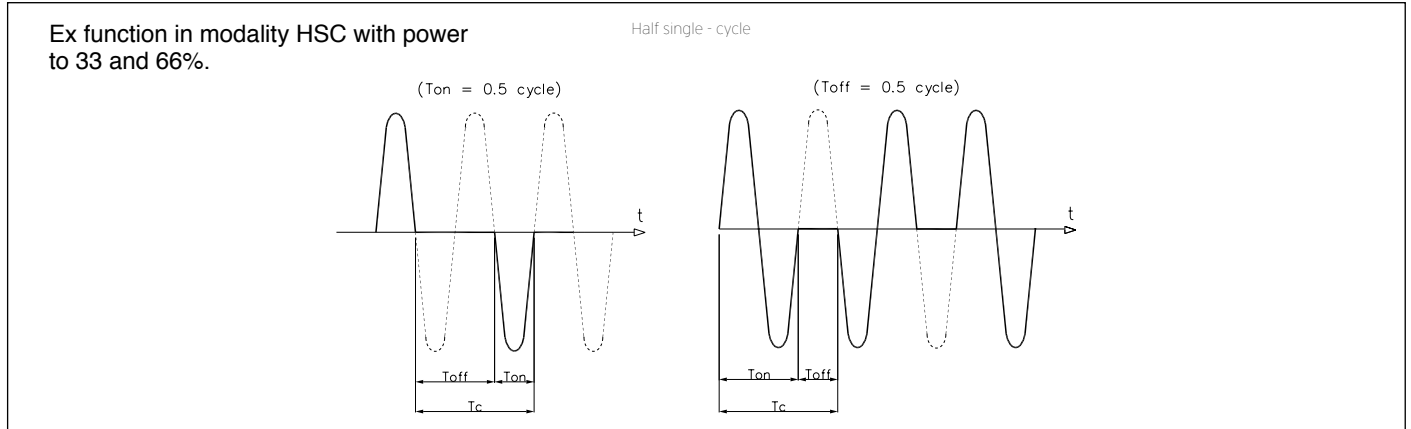

Softstart or Ramp at power-on

This type of start can be enabled in either phase control or pulse train mode, mon-phase.

With phase control, the increment of firing angle stops at the corresponding power value to be transferred to the load.

The control of maximum current spike can be enabled during the ramp phase (this is useful in case of short circuit on the load or loads with other temperature coefficients to automatically adjust the start time of the load).

The ramp is automatically re-enabled if the GTF remains off for a (settable) time

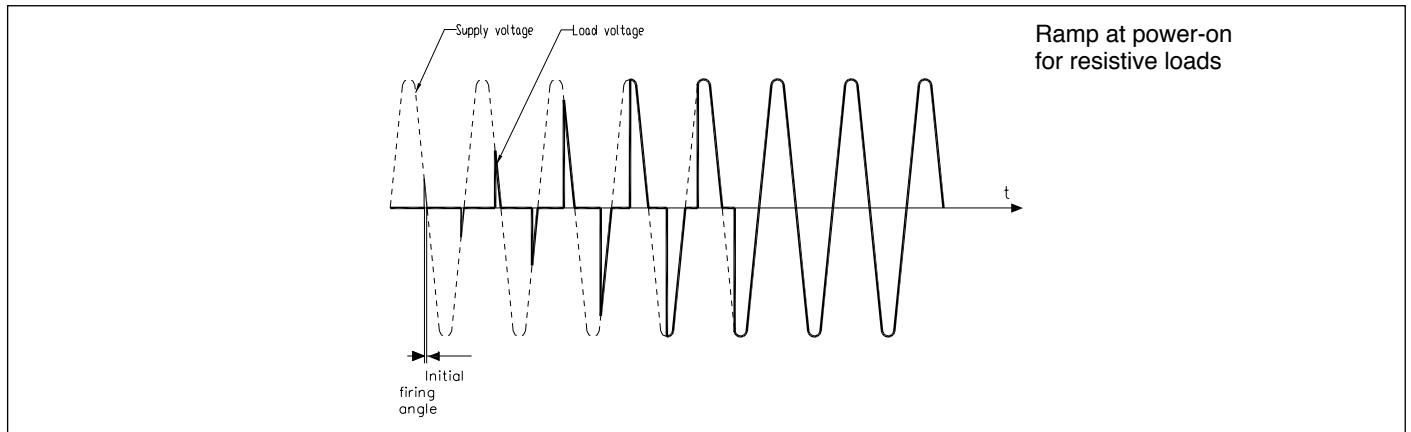

DT - Delay triggering of first cycle (only for control modes ZC, BF mon-phase)

Settable from 0° to 90°.

Useful for inductive loads (transformer primaries) to prevent current spike that could in certain cases trip the high-speed fuses that protect the SCRs.

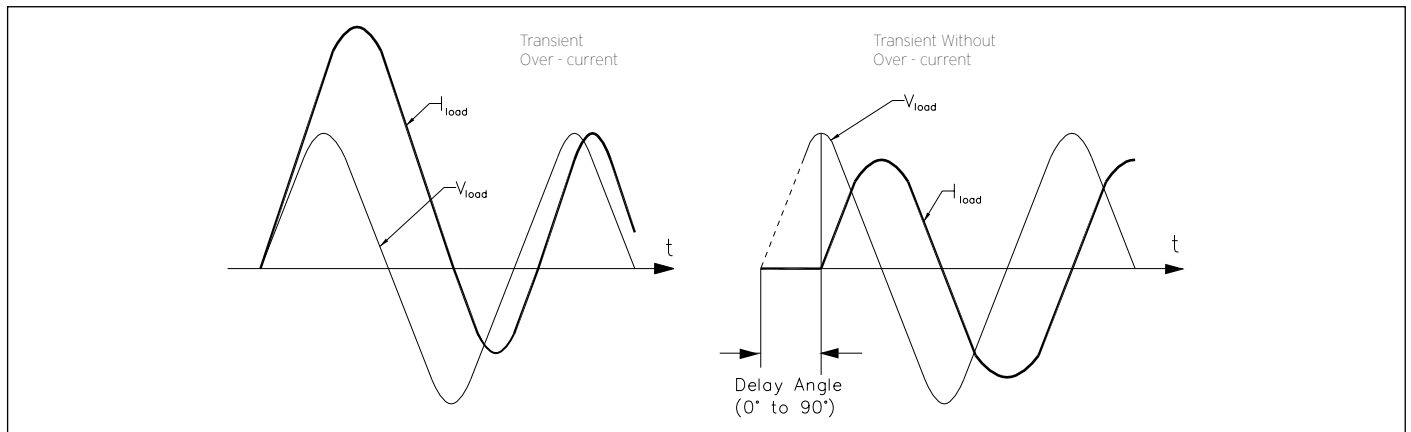

TECHNICAL DATA

General features

Category of use: AC51, AC55b, AC56a

Load type:

AC51 resistive or low-inductance loads

AC55b infrared lamp

AC56a transformers, resistive loads with high temperature coefficient

Switch-on modes:

ZC Zero crossing constant cycle time (1-200sec)

BF Burst Firing variable cycle time (GTT) minimum or optimized

HSC Half Single Cycle corresponds to Burst Firing that manages Semi-cycles of on and off. Useful to reduce flickering with short-wave infrared loads

PA Phase Angle

Nominal voltage:

480Vac (max range 90-530Vac)

600Vac (max range 90-660Vac)

690Vac (max range 90-760Vac)

Nominal frequency: 50-60Hz

Non-repetitive voltage:

1200Vpk (models 480Vac)

1600Vpk (models 600Vac/690Vac)

Control analog input

Voltage: 0...5Vdc, 0...10Vdc

(impedance >100K Ω)

Current: 0...20mA, 4...20mA

(impedenza 125 Ω)

Potentiometer: from 1k Ω to 10k Ω

(auto-fed by 5V by GTF)

Digital inputs

Range 5-30V max 7mA

PWM input control: max 100Hz

(Configurable Features).

Voltage line range:

Range: 90... V_nominal_product

Frequency: 50-60Hz

Accuracy: 2% f.s

Current load range:

Range: 0... 2* I_nominal_product

Accuracy: 3% f.s

Sampling 0,2 msec

HB alarm output (optional)

The HB function detects partial or total load interruption.

The control measures load current by means of an internal device.

The current limit value is set via an automatic procedure activated with the HB button located near the upper connector.

The alarm output is obtained by means of a solid relay, with normally open contact (max 30V, 150mA, maximum conduction resistance 15 Ω).

Modbus RS485 serial (optional)

This option lets you connect the device to a PC, PLC, HMI with a simple RJ10 telephone wire, by using an RS485 serial line with Modbus protocol.

The Baud-Rate is configurable from 1200 Baud to 19200 Baud.

A pair of rotary-switches lets you quickly assign the node address.

A dip-switch near the rotary-switches lets you internally insert the line termination resistance.

Isolation 300V

OUTPUTS

IsolationHV

Rated isolation voltage input/output: 4000Vac

GTF 25 (SCR)

Nominal current 25 Arms @ 40°C

in continuous service.

Non-repetitive overcurrent t=10ms: 400 A

I²t for blowout: 450 A²s

dV/dt critical: 1000 V/ μ s

GTF 40 (SCR)

Nominal current 40 Arms @ 40°C in

continuous service.

Non-repetitive overcurrent t=10ms: 520 A

I²t for blowout: 1800 A²s

dV/dt critical:1000V/ μ s

GTF 50 (SCR)

Nominal current 50 Arms @ 40°C

in continuous service.

Non-repetitive overcurrent t=10ms: 520 A

I²t for blowout: 1800 A²s

dV/dt critica: 1000V/ μ s

GTF 60 (SCR)

Nominal current 60Arms @ 40°C

in continuous service.

Non-repetitive overcurrent t=10ms:

1150 A

I²t for blowout: 6600 A²s

dV/dt critical: 1000V/ μ s

GTF 75 (SCR)

Nominal current 75Arms @ 40°C

in continuous service.

Non-repetitive overcurrent t=10ms:

1150 A

I²t for blowout: 6600 A²s

dV/dt critical: 1000V/ μ s

GTF 90 (SCR)

Nominal current 90Arms @ 40°C

in continuous service.

Non-repetitive overcurrent t=10ms:

1500 A

I²t for blowout: 11200 A²s

dV/dt critical: 1000V/ μ s

GTF 120 (SCR)

Nominal current 120Arms @ 40°C in continuous service.

Non-repetitive overcurrent t=10ms: 1500 A

I²t for blowout: 11200 A²s

dV/dt critical: 1000V/ μ s

GTF 150 (SCR)

Nominal current 150Arms @ 40°C in continuous service.

Non-repetitive overcurrent t=10ms: 5000 A

I²t for blowout: 125000 A²s

dV/dt critical: 1000V/ μ s

GTF 200 (SCR)

Nominal current 200 Arms @ 40°C in continuous service.

Non-repetitive overcurrent t=10ms: 8000 A

I²t for blowout: 320000 A²s

dV/dt critical: 1000V/ μ s

GTF 250 (SCR)

Nominal current 250Arms @ 40°C in continuous service.

Non-repetitive overcurrent t=10ms: 8000 A

I²t for blowout: 320000 A²s

dV/dt critical: 1000V/ μ s

Thermic Dissipation:

GTF models without electric fuse (with internal SCR) dissipate thermic power based on load current:

Pdissipation = I_load_Arms * 1.3V (W)

For 150, 200, 250 A models with integrated fuse, also consider dissipated power at rated current shown on the fuse table GTF models with electronic fuse (with internal IGBT) dissipate thermic power based on load current:

Pdissipation = I_load_Arms * 2.8V (W)

Electronic fuse (optional)

This option eliminates the need for an external extra-rapid fuse to protect the device.

In case of load short-circuit, the internal IGBT device is instantaneously switched off and the alarm status is signaled.

LED

N.5 LEDs indicator:

RUN (green)

STATUS (yellow)

ALARM (red)

DIGITAL INPUT (yellow)

ON / OVER-TEMP. (green / yellow)

Power supply (model GTF 25-120A)

24Vdc/Vac +/-25%
 Input @ 25Vdc: max 100mA
 Power: max 3VA
 Maximum voltage insulation from control signals: 300 V

Power supply (model GTF 150-250A)

24Vdc/Vac +/-25%
 Input @ 25Vdc: max 450mA
 Power: max 11VA
 Maximum voltage insulation from control signals: 300 V

Fan Power supply**(only for model GTF 120A):**

24Vdc/+/-10%
 Input @ 25Vdc: max 200mA

Ambient conditions:

Working temperature: 0-50°C (see the derating curve)
 Storage temperature: -20°C - +70°C
 Max. relative humidity: 85% not condensing
 Max. installation altitude: 2000m slm
 Pollution level: 2

Installation

For models 25-120A bar DIN EN50022
 For models 150-250A panel

Dimensions:

see dimensions and installation

Weight

GTF 25/40	0,81 Kg
GTF 50/60	0,97 Kg
GTF 75/90	1,3 Kg
GTF 120	1,5 Kg
GTF 25 El. Fuse	0,97 Kg
GTF 40/50 El. Fuse	1,1 Kg
GTF 60 El. Fuse	1,5 Kg
GTF150/200/250 with integrated fuse	2,6 Kg





ELECTRICAL CONNECTION

POWER CONNECTION

RECOMMENDED WIRE GAUGES

GTF CURRENT LEVEL	TERMINAL	CABLE WIRE	WIRE TERMINAL	TIGHTENING TORQUE / TOOL
25A	1/L1, 2/T1, PE	4 mm ²	Wire terminal / Eye D. 6mm	2 ...2.5 Nm / Phillips screwdriver PH2 - PH3
40A	1/L1, 2/T1, PE	10 mm ²	Wire terminal / Eye D. 6mm	2 ...2.5 Nm / Phillips screwdriver PH2 - PH3
50A	1/L1, 2/T1, PE	10 mm ²	Wire terminal / Eye D. 6mm	2 ...2.5 Nm / Phillips screwdriver PH2 - PH3
60A	1/L1, 2/T1, PE	16 mm ²	Wire terminal / Eye D. 6mm	2 ...2.5 Nm / Phillips screwdriver PH2 - PH3
75A	1/L1, 2/T1, PE	25 mm ²	Wire terminal / Eye D. 6mm	2 ...2.5 Nm / Phillips screwdriver PH2 - PH3
90A	1/L1, 2/T1, PE	35 mm ²	Wire terminal / Eye D. 6mm	2 ...2.5 Nm / Phillips screwdriver PH2 - PH3
120A	1/L1, 2/T1, PE	50 mm ²	Wire terminal / Eye D. 6mm	2 ...2.5 Nm / Phillips screwdriver PH2 - PH3
-	3/L2 (Ref. Vline)	0.25 ...2.5 mm ²	wire terminal tip	0.5 ...0.6 Nm / Screwdriver blade 0.6 x 3.5 mm
150A	1/L1, 2/T1	70 mm ²	Wire stripped for 25 mm or with crimped pre-insulated terminal tube CEMBRE PKC70022	4 ... 5 Nm / No. 6 hex head wrench
200A	1/L1, 2/T1	95 mm ²	Wire stripped for 25 mm or with crimped pre-insulated terminal tube CEMBRE PKC95025	4 ... 5 Nm / No. 6 hex head wrench
250A	1/L1, 2/T1	120 mm ²	Wire stripped for 25 mm	4 ... 5 Nm / No. 6 hex head wrench
-	3/L2 (Ref. Vline)	0.25 ...2.5 mm ²	Wire stripped for 8 mm or with tag terminal	0.5 ...0.6 Nm / Flat-head screwdriver tip 0,6 x 3.5 mm

SIGNAL CABLE

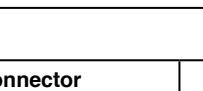
GTF 25-120: J1		0,2 - 2,5mm ²	24 - 14AWG
			
GTF 150-250: J1, J2, J4		0,25 - 2,5mm ²	23 - 14AWG
GTF 150-250: J5, J7			
GTF 150-250: J3		0,14 - 0,5mm ²	28 - 20AWG
		0,25 - 0,5mm ²	23 - 20AWG

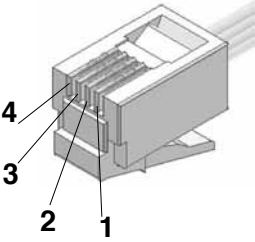
	Connector RJ10 4-4 pin	Nr. Pin	Name	Description	Note
RS 485		1	GND1 (**)		(**) Insert the line termination in the last device on the Modbus line.
		2	Tx/Rx+	Data reception/transmission (A+)	
		3	Tx/Rx-	Data reception/transmission (B-)	
		4	+V (riservato)		

Cable type: flat telephone cable for pin 4-4 conductor 28AWG

ORDERING CODE

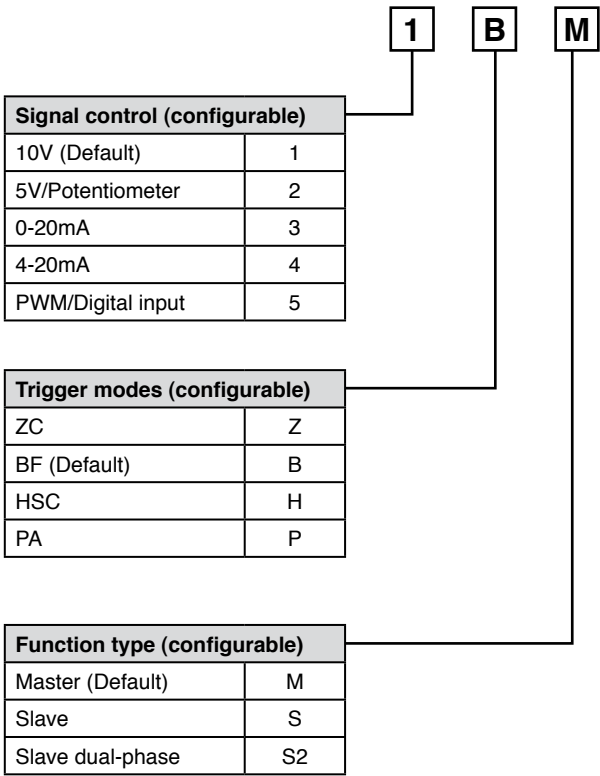
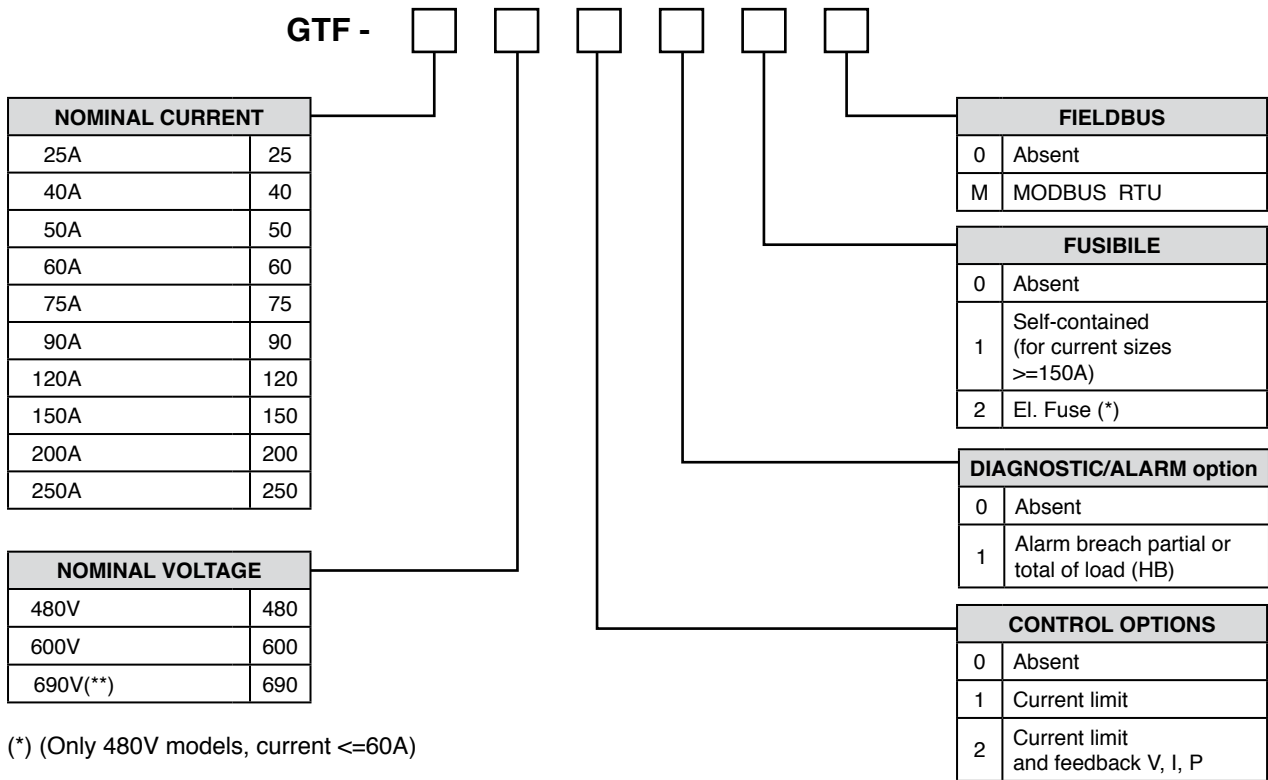

GEFRAN spa reserves the right to make aesthetic or functional changes at any time and without notice

ACCESSOIRES

CONFIGURATION KIT



Configuration kit for standard GTF (via the TTL port) by means of PC with RS232 serial line (Windows environment).

Lets you read or write all of the parameters of a single GTF

A single software for all models

- Easy and rapid configuration
- Saving and management of parameter recipes
- On-line trend and saving of historical data

Component Kit:

- Connection cable PC RS232 <-> GTF port TTL
- CD SW GF Express installation

ORDERING CODE

GF_eXK-0-0-0.....Cod. F043956

FUSE / FUSEHOLDERS

Model	EXTRARAPID FUSES				FUSEHOLDERS
	Size I ² t	Sign Form	Model Code	Power dissipation @ In	Adoption Acronym Code
GTF 25	25A 390A ² s	FUS-025 10x38	FWC25A10F 338474	6W	PFI-10X38 337134 UR30A@690V
GTF 40... GTF 50...	50A 1600A ² s	FUS-050 22x58	FWP50A22F 338127	9W	PFI-22X58 337223 UR80A@600V
GTF 60...	63A 3080A ² s	FUS-063 22x58	FWP63A22F 338191	11W	PFI-22X58 337223 UR80A@600V
GTF 75...	80A 6600A ² s	FUS-080 22x58	FWP80A22F 338199	14W	PFI-22X58 337223 UR80A@600V
GTF 90...	125A 6950A ² s	FUS-125N	660RF00AT125 338106	25W	PF-din 337092 UR400A@1000V
GTF 120...	125A 6950A ² s	FUS-125N	660RF00AT125 338106	25W	PF-din 337092 UR400A@1000V
GTF 150...	200A 31500A ² s		DN000UB69V315 338930	19W	WITHOUT FUSEHOLDER
GTF 200...	450A 196000A ² s		DN00UB60V450L 338932	35W	WITHOUT FUSEHOLDER
GTF 250...	450A 196000A ² s		DN00UB60V450L 338932	35W	WITHOUT FUSEHOLDER

ACCESSOIRES

A wide range of accessories is available (including fuses and fuse holders, supports for fastening DIN bar, ID plates, thermostats, current transformers and isolation transformers).

To choose accessories, see the section "Solid state relays - Accessories."

• WARNINGS



WARNING: this symbol indicates danger.

Before installation, please read the following advices:

- follow the indications of the manual scrupulously when making the connections to the instrument.
- use a cable that is suitable for the ratings of voltage and current indicated in the technical specifications.
- if the instrument is used in applications where there is risk of injury to persons and damage to machines or materials, it is essential that it is used with an auxiliary alarm device.

It is advisable to verify frequently that the alarm device is functional even during the normal operation of the equipment.

- The instrument must NOT be used in environments where there could be the presence of dangerous atmospheres (inflammable or explosive).
- During continuous operation, the heatsink may reach 100°C and remain at a high temperature due to thermal inertia even after the device is switched off. Therefore, DO NOT touch the heat sink or the electrical wires.
- do not operate on the power circuit unless the main supply is disconnected.
- DO NOT open the cover if device is "ON"!

(use the holes in the cover for eventual re-calibration).

Installatio:

- connect the device to the ground using the proper ground terminal.
- the power supply wiring must be kept separate from that of inputs and outputs of the instrument; always check that the supply voltage corresponds to that indicated on the instrument cover.
- Delete this line entirely.
- keep away from dust, humidity, corrosive gases and heat sources.
- The connection cable must be shorter than 3 meters if the current transformer is used.

Maintenance: Check the correct operation of the cooling fans at regular intervals; clean the ventilation air filters of the installation at regular intervals.

- Repairs must be performed only by specialized or appropriately trained personnel. Cut off power to the device before accessing internal parts.
- Do not clean the box with solvents derived from hydrocarbons (trichloroethylene, gasoline, etc.). Using such solvents will compromise the mechanical reliability of the device. To clean external plastic parts, use a clean cloth wet with ethyl alcohol or water.

Technical service: GEFFRAN has a technical service department. Defects caused by use not conforming to the instructions are excluded from the warranty.

GEFRAN spa reserves the right to make any kind of design or functional modification at any moment without prior notice



This device conforms to TÜV with reference to: EN61010-1, EN 60947-4-3/A2, EN 60947-1/A1



This device conforms to European Union Directive 2004/108/CE e 2006/95/CE with reference to generic standards: EN 60947-4-3 (product) EN 61010-1 (safety)

GEFRAN

GEFRAN spa
via Sebina, 74 - 25050 Provaglio d'Isèo (BS)
Tel. 030988881 - fax 0309839063- Internet: <http://www.gefran.com>

DTS_GTF_11-2012_ENG